

DOME CAMERA

TDC-327QS2SD5, TDC-327QS2FD5

600TVL/D-WDR MINI VANDAL DOME CAMERA



TDC-327QS2SD5
Surface Mount Type



TDC-327QS2FD5
Flush Mount Type

- FEATURES -

- 1/3" SONY High-Resolution Super HAD II CCD
- 600TV Lines Horizontal resolution
- Excellent low light sensitivity of 0.3Lux/F1.2
- Digital WDR : Digital Wide Dynamic Range
- DNR : Digital Noise Reduction
- HLC : High Light Compensation
- Blemish Compensation : 64 Points
- Lens Shading
- Parking Line
- IR Smart Day & Night
- Motion Detection : 4 Zone
- Privacy : 8 Zone
- Board Lens f=3.6mm
- IP66 Weather Proof Type
- Vandal Proof Dome Housing
- Compact Design



1/3 SONY
SUPER HAD II CCD



DAY & NIGHT



DIGITAL
WDR
DIGITAL WIDE
DYNAMIC RANGE



DNR
DIGITAL NOISE
REDUCTION



HLC
HIGH-LIGHT
COMPENSATION



AUTO IRIS



BOARD LENS



VANDAL PROOF



IP 66



DC 12V

- DIMENSION -

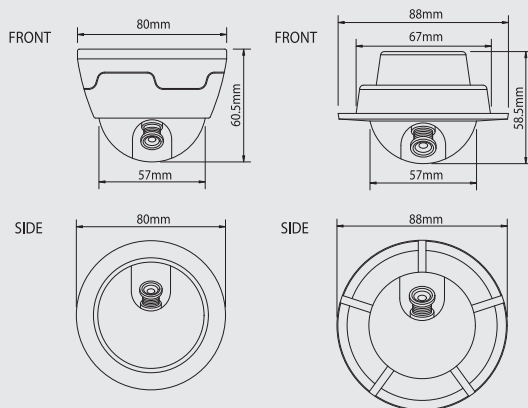

- CONNECTION -

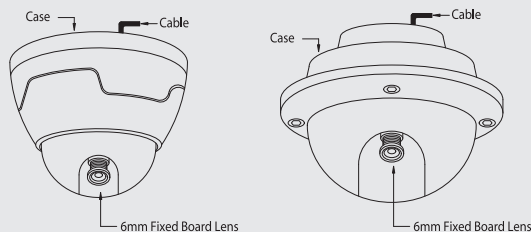

- SPECIFICATIONS -

TDC-327QS2SD5 / TDC-327QS2FD5		
Signal Format	NTSC	PAL
Horizontal Resolution	600TV Lines	
Image Sensor	1/3" SONY High-Resolution Super HAD II CCD	
Total Pixels	811(H) x 508(V)	795(H) x 596(V)
Effective Pixels	768(H) x 494(V)	752(H) x 582(V)
Scanning System	2:1 Interlace	
Synchronization	Internal	
Scanning Frequency	15.734 KHz(H), 59.94 Hz(V)	15.625 KHz(H), 50.00 Hz(V)
Video Output	CVBS : 1.0Vp-p/75Ω	
Min. Illumination	0.3Lux/F1.2	
Electronic Shutter	1/60 ~ 1/100,000 sec	1/50 ~ 1/100,000 sec
Iris Control	Manual	
Signal to Noise Ratio	52dB (AGC Off, Weight : On)	
Backlight Compensation	BLC / HLC / OFF	
White Balance	ATW1 (2,300°K ~ 9,500°K) / ATW2 (2,000°K ~ 11,000°K) / MANUAL	
Gain Control	LOW / HIGH / OFF	
DNR	ON / OFF (Level Adjustable)	
Day & Night	ON (IR SMART) / OFF	
Digital WDR	ON / OFF	
Motion Detection	ON / OFF (4 Zone, 48x15)	
Privacy	ON / OFF (8 Zone)	
Horizontal Mirror	ON / OFF	
Lens Shading	ON / OFF	
Parking Line	User setting (LT, LB, RT, RB, F, N, T)	
OSD	Built-in (English, China)	
Lens	Board Lens f=3.6 (Option : 4.0 / 6.0 / 8.0 / 12.0mm)	
Input Voltage	DC 12V (±10%)	
Power Consumption	Max. 2.0W	
Operating Temp/Hum	Temperature : -10°C ~ +50°C / Humidity : 30% ~ 80% RH	
Storage Temp/Hum	Temperature : -10°C ~ +50°C / Humidity : 30% ~ 80% RH	
Dimension (mm)	TDC-327QS2SD5 : 80.0(∅)x60.5(H) / TDC-327QS2FD5 : 88.0(∅)x58.5(H)	
Weight	TDC-327QS2SD5 : Approx. 255g / TDC-327QS2FD5 : Approx. 190g	