

IR LED CAMERA

TEM-422H, TEM-422HX

IP67 24PCS IR LED CAMERA



IP 67



- FEATURES -

- 1/3" SONY DSP Super HAD B/W CCD
- 600TV Lines Horizontal Resolution
- 24pcs IR LED for night vision (Day & Night)
- Visibility Range : 15~20m
- Board Lens : 3.6mm/F2.0
- IP 67

* **TEM-422HX** : 600TV Lines, EX-View CCD



1/3 SONY DSP Super HAD CCD



B/W



3.6mm BOARD LENS



24pcs IR LED



DAY & NIGHT



IP 67

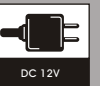

DC 12V

- DIMENSION -

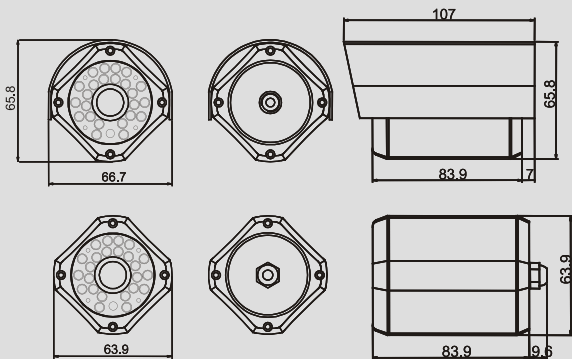

- BRACKET -



- SPECIFICATION -

TEM-422H		
Signal Format	EIA	CCIR
Horizontal Resolution	600TV Lines	
Image Sensor	1/3" SONY DSP Super HAD CCD	
Scanning System	525 lines interlaced	625 lines interlaced
Synchronization	Internal	
Video Output	CVBS : 1.0Vp-p/75Ω	
Min. Illumination	0Lux	
Signal to Noise Ratio	45 dB or more (AGC Off)	
Gamma	0.45	
AGC	On	
Input Voltage	DC 12V (±10%)	
Power Consumption	IR LED OFF : Max 1.3W or less IR LED ON : Max 2.4W or less	
Operating Temperature	-10°C to +55°C	
Storage Temperature	-20°C to +70°C	
Operating Humidity	Under 90% Non-condensing	
Storage Humidity	Under 90% Non-condensing	
Lens	Board Lens : 3.6mm/F2.0	
Option Lens	Board Lens : 6.0mm, 8.0mm	
Dimension	66.7(W) x 65.8(H) x 107(D)mm	
Weight	328g	