

SQUARE CAMERA

TSM-S35H, TSM-S35HX Series B/W SQUARE CAMERA



- FEATURES -

- TSM-S35H : 1/3" SONY DSP Super HAD B/W CCD
TSM-S35HX : 1/3" SONY DSP EX-View B/W CCD
- 600TV Lines
- 35x35mm Size Miniature Camera
- Audio Amplifier and microphone (Optional)
- TSM-S35H : 0.01Lux/F1.2
TSM-S35HX : 0.0003Lux/F1.2
- Automatic Gain Control
- Electronic Shutter
- Strong Compatibility with Various Lens Types
- Reverse Polarity Power Input Safety Circuit



- LENS OPTION -



Board Lens
- TSM-S35HB
- TSM-S35HXB



Conical Pinhole Lens
- TSM-S35HCP
- TSM-S35HXCP

- DIMENSION -

TSM-S35 / TSM-S35X Series

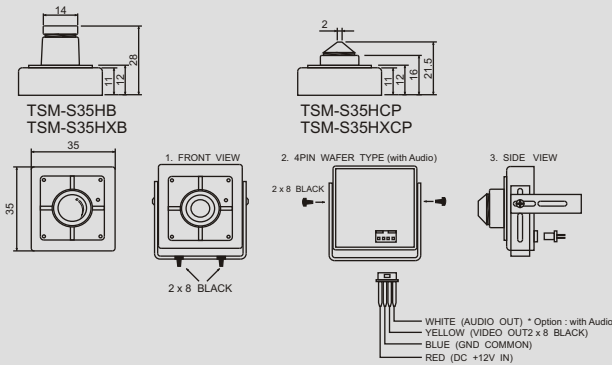

- SPECIFICATION -

TSM-S35H / TSM-S35HX Series		
Signal Format	EIA	CCIR
Horizontal Resolution	600TV Lines	
Image Sensor	TSM-S35H : 1/3" SONY DSP Super HAD B/W CCD TSM-S35HX : 1/3" SONY DSP EX-View B/W CCD	
Scanning System	525 lines interlaced	625 lines interlaced
Synchronization	Internal	
Video Output	Standard composite 1Vp-p composite video into 75Ω	
Min. Illumination	TSM-S35H : 0.01Lux/F1.2, TSM-S35HX : 0.0003Lux/F1.2	
Signal to Noise Ratio	45dB or more (AGC Off)	
Gamma	0.45	
AGC	On	
Input Voltage	DC 12V (±10%) / 1.8W	
Case Material	Metal	
Operating Temperature	-10°C to +55°C	
Operating Humidity	Under 85% Non-condensing	
Lens Option	Board Lens, Conical Pinhole Lens	
Dimension	35(W) x 35(H) mm	
Weight	48g	
Accessory	Mounting Bracket / 2 Screws - Included DIY Cable (Video-BNC, Power-DC, 30cm) - Optional	
Option	Audio	