

DOME CAMERA

ZVC-3242QS

Φ80 MINI DOME CAMERA



- FEATURES -

- 1/3" SONY DSP Super HAD High-Resolution CCD
- 550TV Lines Horizontal Resolution
- Excellent Low Light Sensitivity of 0.3Lux/F1.2 (AGC High, DNR High) Sens-up 0.002Lux (x128)
- DNR : Digital Noise Reduction (30% Less HDD)
- Auto Day/Night On
- Dome size : Φ80mm

Option

- Wall Mount Bracket : MBR-300WM



1/3 SONY SUPER HAD CCD



COLOR



DAY & NIGHT



DNR DIGITAL NOISE REDUCTION



SENS-UP SENS-UP 0.002 Lux



BOARD LENS



AUTO-IRIS



ELECTRONIC SHUTTER



VANDAL PROOF



DC 12V

- DIMENSION -

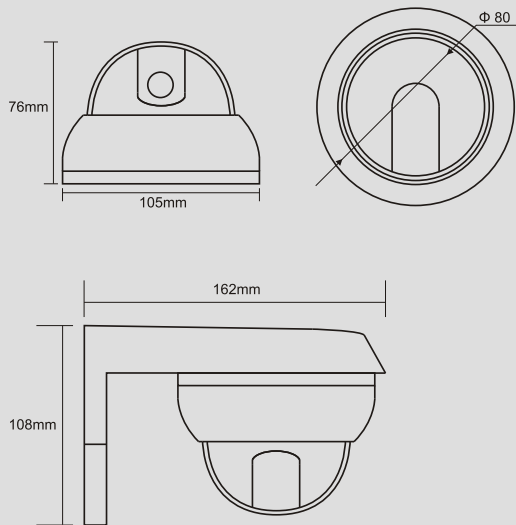

- WALL MOUNT BRACKET -



MBR-300WM

- SPECIFICATION -

ZVC-3242QS		
Signal Format	NTSC	PAL
Horizontal Resolution	550TV Lines	
Image Sensor	1/3" SONY DSP Super HAD CCD	
Scanning System	2:1 Interlace	
Synchronization	Internal / Line-Lock	
Video Output	Standard composite 1Vp-p composite video into 75Ω	
Min. Illumination	0.3Lux/F1.2 (50IRE); Color / 0.002Lux/F1.2(50IRE)	
Signal to Noise Ratio	50dB (AGC Off, Weight On) Confirm the E/S step	
Electronic shutter	ESC (x128~1/60~1/20000sec)	
Day & Night	ON / AUTO (Day : Color, Night : B/W)	
OSD Control	IRIS, White Balance, DNR, Electronic shutter, Privacy, Camera Title, Back Light Compensation	
Input Voltage	DC 12V (±10%), MAX 2.0W	
Housing Material	Vandal Proof Dome	
Operating Temperature	-10°C to +55°C	
Operating Humidity	Under 85% Non-condensing	
Lens	Board Lens	
Dimension	105(Φ) x 76(H) mm	
Weight	Approx. 360g, W/Bracket : 720g	
Option	MBR-300WM, OSD control board	